

tropicair

DUO

Ultra Low Emission Burner

- ULEB's are the most environmentally friendly fire for your home
- Designed & made in Canterbury NZ
- Clean air approved in all zones
- Cook top
- Wetback approved
- Heats a 3-4 bedroom home
- Highly efficient - *less wood, more heat*
- **Upgrades available**
 - Woodbox base
 - Coloured side panel and/or flue

shimmering
rose

brushed
stainless



hearth and flue sold separately



CONTACT US FOR MORE INFO

p: 03 379 0438

e: sales@tropicaire.co.nz



www.tropicaire.co.nz

Dimensions	970H, (1170 Woodbox) 620W, 365D
Weight	131.5KG
ULEB approved	Yes
Clean Air Approved	All Zones
Hearth	LB (low base):Insulated WB (woodbox) Ash
CM1 Efficiency	74%
CM1 Emissions	0.35g/KG
CM1 Emission / Heat Output	23mg/MJ
NES Efficiency	79%
NES Emissions	0.1g/KG
NES Emission / Heat Output	9mg/MJ
Minimum Avg Output	10.4KW
Maximum Avg Output	14.6KW
Peak During Emission Tests	15.2KW
Wetback KW Output	2.2KW

WALL INSTALLATION

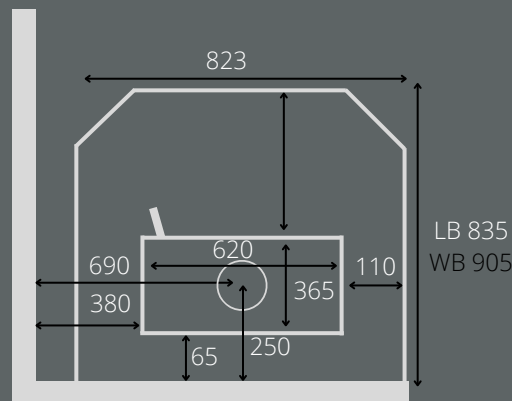

clearances in mm to combustibles
Clearances to combustibles are absolute minimums.
Where practical these should be exceeded.

CORNER INSTALLATION

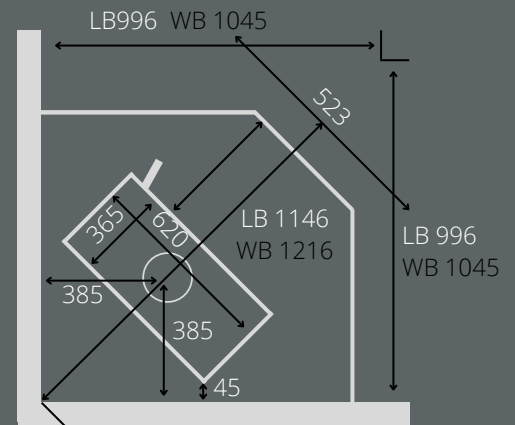

WETBACK PIPE POSITIONING



Wetback changes rear clearances under AS/NZS2918:2001



For more information about our clearances check out our installation instructions on our website

WB (woodbox) uses an ash hearth. LB (low base) must have 46mm insulating hearth